

NS-HP-GN2 User's Guide



Rev. 0.9
June 20, 2022

Table of Contents

1.	INTRODUCTION	3
2.	FEATURES OF NS-HP-GN2	5
3.	APPLICATIONS.....	6
4.	PIN OUT DESCRIPTION.....	7
5.	CHECK OUT BASIC GPS FUNCTIONALITY	9
6.	SET UP NS-HP-GN2 AS RTK BASE	13
	Known Base Antenna Position	14
	Unknown Base Antenna Position.....	15
	Base Stream Format.....	17
7.	USE NS-HP-GN2 AS RTK ROVER	20
8.	MOVING BASE MODE	26
9.	ADVANCED MOVING BASE MODE	29
10.	ACTIVE ANTENNA CONSIDERATION	32
11.	FIRMWARE UPDATE	33
12.	POSSIBLE CONNECTION FOR QUADCOPTER APPLICATION	35
	CHANGE LOG.....	37

1. INTRODUCTION

NS-HP-GN2 is a high performance multi-band multi-GNSS RTK receiver. It can accept RTCM 3.x message or SkyTraq carrier phase raw measurement data from a base station to perform carrier phase RTK processing, achieving centimeter-level accuracy relative positioning.

When used with RTCM base station, the supported RTCM message types are:

Type 1004 – Extended L1/L2 GPS RTK observables

Type 1005 – Stationary RTK Reference Station ARP

Type 1012 – Extended L1/L2 GLONASS RTK observables

Type 1033 – Receiver and antenna description

Type 1074 –GPS MSM4

Type 1075 – GPS MSM5

Type 1076 – GPS MSM6

Type 1077 – GPS MSM7

Type 1084 – GLONASS MSM4

Type 1085 – GLONASS MSM5

Type 1086 – GLONASS MSM6

Type 1087 – GLONASS MSM7

Type 1094 – Galileo MSM4

Type 1095 – Galileo MSM5

Type 1096 – Galileo MSM6

Type 1097 – Galileo MSM7

Type 1114 – QZSS MSM4

Type 1115 – QZSS MSM5

Type 1116 – QZSS MSM6

Type 1117 – QZSS MSM7

Type 1124 – BeiDou MSM4

Type 1125 – BeiDou MSM5

Type 1126 – BeiDou MSM6

Type 1127 – BeiDou MSM7

Type 1230 – GLONASS Code Phase Biases

For centimeter-level RTK accuracy, NS-HP-GN2 requires much better operating condition than conventional meter-level accuracy GPS receiver:

- * Under open sky without interference
- * Signal level over 37dB/Hz
- * 8 or more satellites above 15 degree elevation angle with good satellite geometry

If above condition is not met, NS-HP-GN2 will not get centimeter-level accuracy RTK solution.

Without base station data input, NS-HP-GN2 works like a normal GNSS receiver.

When used with a RTCM 3.x Virtual Reference Station (VRS) RTK base, one rover NS-HP-GN2 is needed. If one wishes to setup a local base station to work with rover, then two NS-HP-GN2 will be needed, one for base and another for rover.

Default NMEA output baud rate is 115200.

Rover expects RTCM 3.x or SkyTraq raw measurement data at input baud rate of 115200

2. FEATURES OF NS-HP-GN2

RTK Receiver Features

- * Support RTK base and rover modes
- * Supports GPS/QZSS L1/L2C + Beidou B1I/B2I + Galileo E1/E5b + GLONASS L1/L2 RTK
- * RTK position accuracy: 1cm + 1ppm
- * RTK initialization time: < 10sec
- * 100mA @ 3.3V

3. APPLICATIONS

NS-HP-GN2 may be used for:

1. GIS data collection
2. Precision farming machine guidance
3. Precision grass cutting machine guidance
4. Precision guidance of unmanned aerial vehicles
5. Precise position tracking of race cars for performance measurement

4. PIN OUT DESCRIPTION

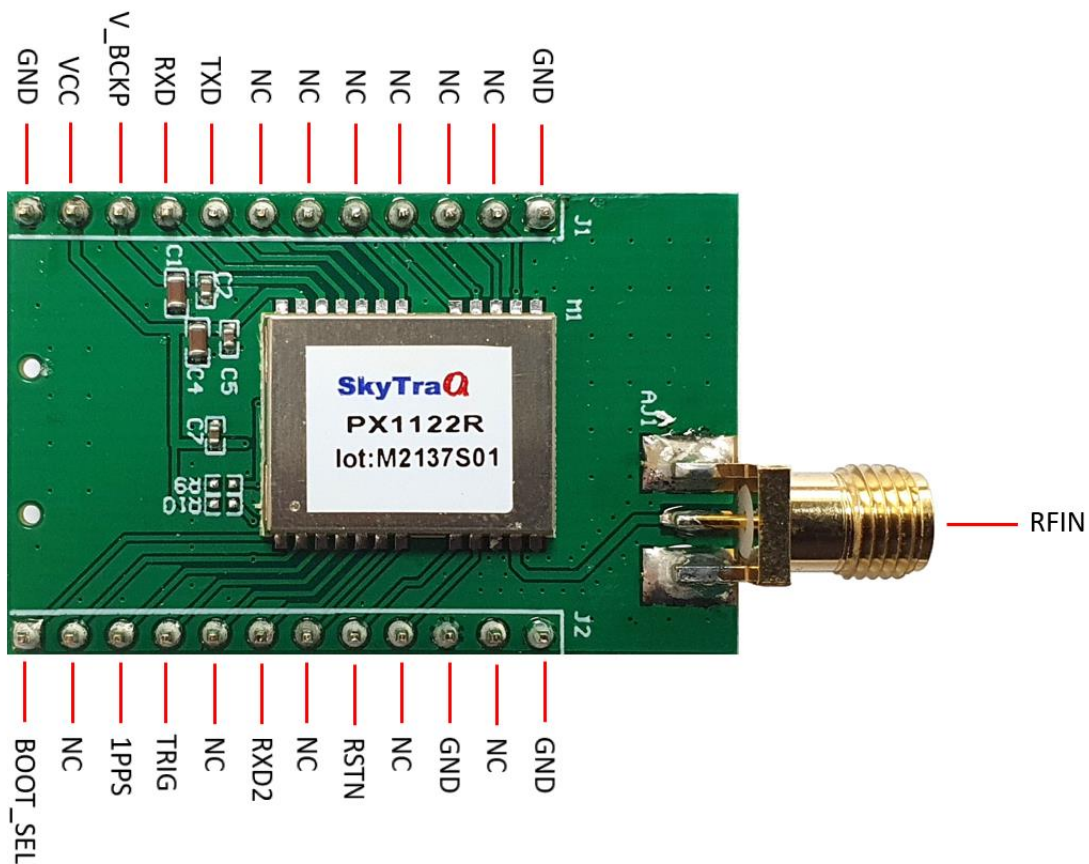

Pin No.	Name	Description
J1		
1	BOOT_SEL	No connection for normal use. Pull-low for loading firmware into empty or corrupted Flash memory from ROM mode for the master processor.
2	NC	No connection, empty pin
3	1PPS	One-pulse-per-second (1PPS) time mark output, 3.3V LVTTTL. The rising edge synchronized to UTC second when getting 3D position fix. The pulse duration is about 100msec at rate of 1 Hz.
4	TRIG	External trigger input for generating STI,005 time stamp, 3.3V LV-TTL
5	NC	No connection, empty pin
6	RX2	UART serial data input, 3.3V LVTTTL. One simplex asynchronous serial UART port is implemented. This UART input is used for receiving RTCM-SC104 data or SkyTraQ raw measurement data from the base at 115200.
7	NC	No connection, empty pin
8	RSTN	External active-low reset input to the receiver. Only needed when power supply rise time is very slow or software controlled reset is desired.
9	NC	No connection, empty pin
10	GND	Ground
11	NC	No connection, empty pin

12	GND	Ground
----	-----	--------

Pin No.	Name	Description
J2		
1	GND	Ground
2	NC	No connection, empty pin
3	NC	No connection, empty pin
4	NC	No connection, empty pin
5	NC	No connection, empty pin
6	NC	No connection, empty pin
7	NC	No connection, empty pin
8	TXD	UART serial data output, 3.3V LVTTTL. One full-duplex asynchronous serial UART port is implemented. This UART output is used for sending position, time and velocity information from the receiver in NMEA-0183 format. When idle, this pin output HIGH.
9	RXD	UART serial data input, 3.3V LVTTTL. One full-duplex asynchronous serial UART port is implemented. This UART input is for sending commands or information to the receiver in SkyTraq binary protocol. In the idle condition, this pin should be driven HIGH.
10	V_BCKP	Backup supply voltage for internal RTC and backup SRAM, 1.3V ~ 3.6V. V_BCKP must be applied whenever VCC is applied. This pin should be powered continuously to minimize the startup time. If VCC and V_BCKP are both removed, the receiver will be in factory default mode upon power up, all user configuration set is lost. For applications the does not care cold starting every time, this pin can be connect to VCC.
11	VCC	Power supply, 3.3V DC
12	GND	Ground

5. CHECK OUT BASIC GPS FUNCTIONALITY

Hook up as below, connect to an UART-to-USB bridge breakout board, connect antenna to RF_IN, and place antenna at a location having clear sky view. After driver for the UART-to-USB bridge chip has been installed, select proper COM port and 115200 baud rate on GNSS Viewer, click CLOSE, GNSS Viewer will show signal being acquired and tracked.

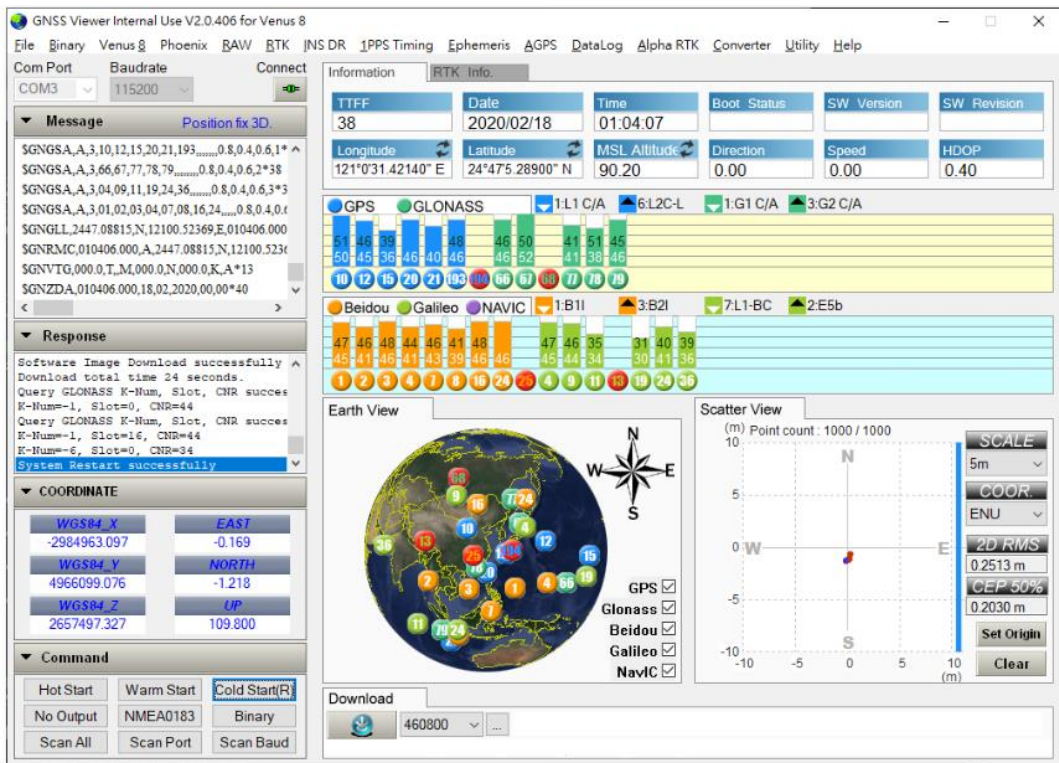
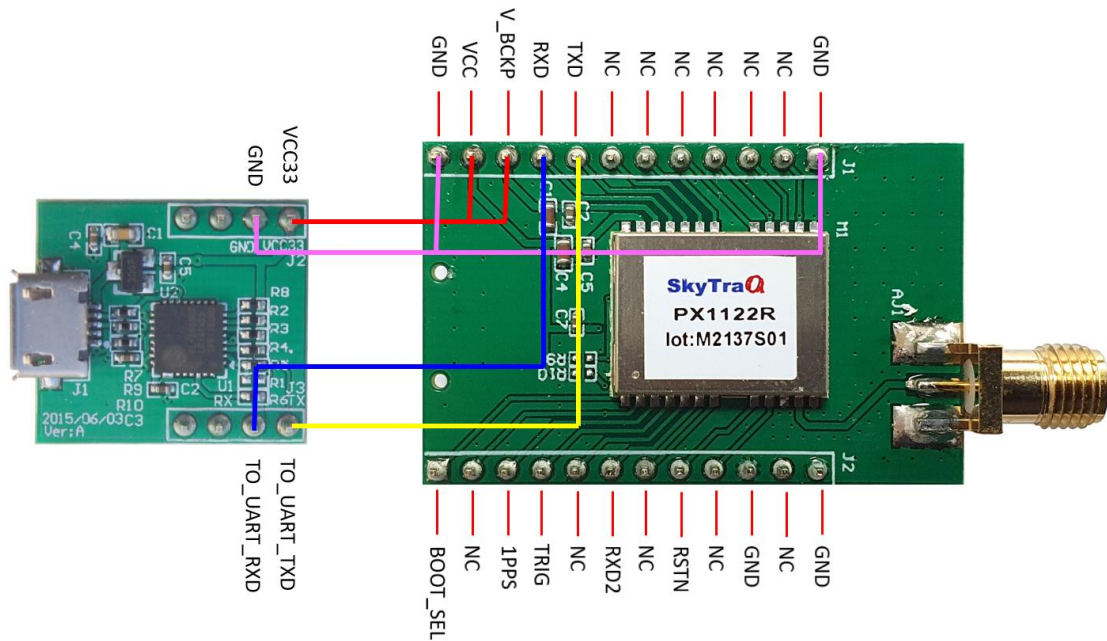

GNSS Viewer for Windows PC can be downloaded from:

http://navspark.mybigcommerce.com/content/GNSS_Viewer.zip

<http://navspark.mybigcommerce.com/content/GNSS-Viewer-User-Guide.rev0.2.pdf>

If uncertain of the COM port, it can be found from the Windows Device Manager.

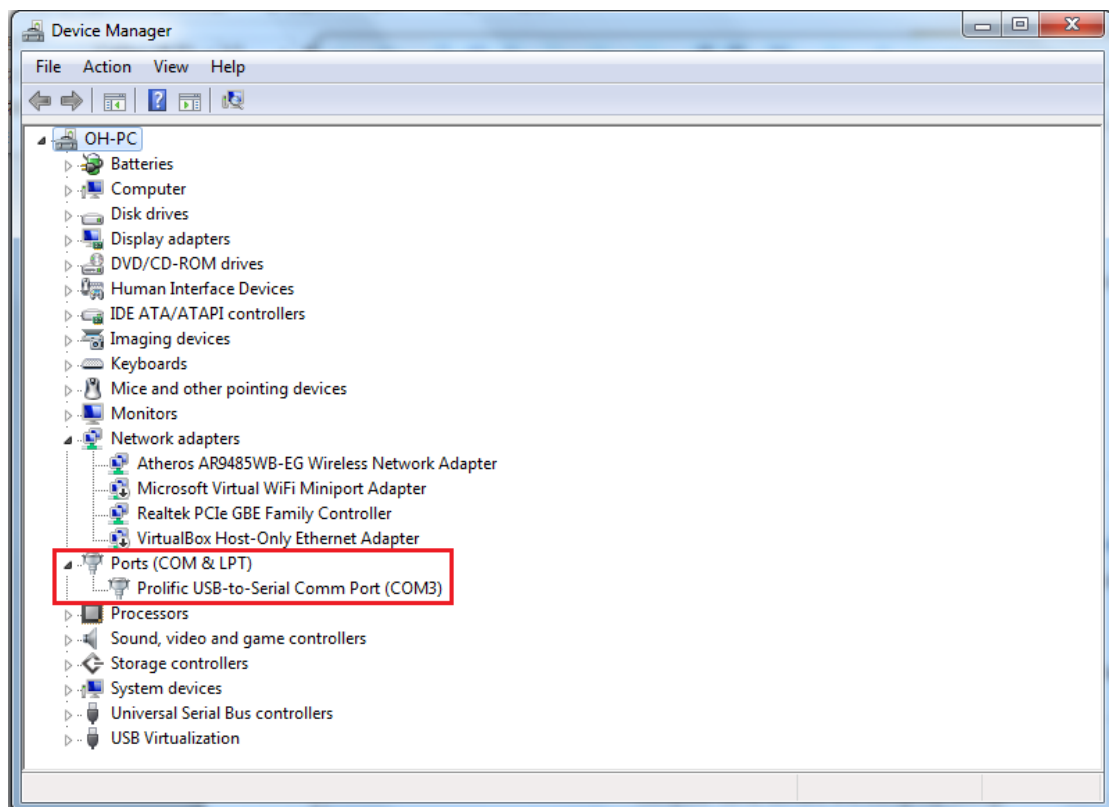

If wishing to change NMEA output baud rate, from Binary pull-down menu select Configure Serial Port, select desired baud rate and Update to SRAM+Flash.

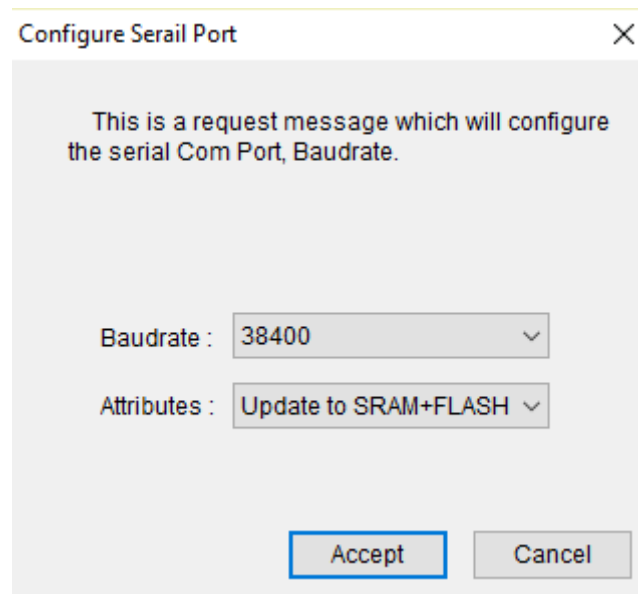
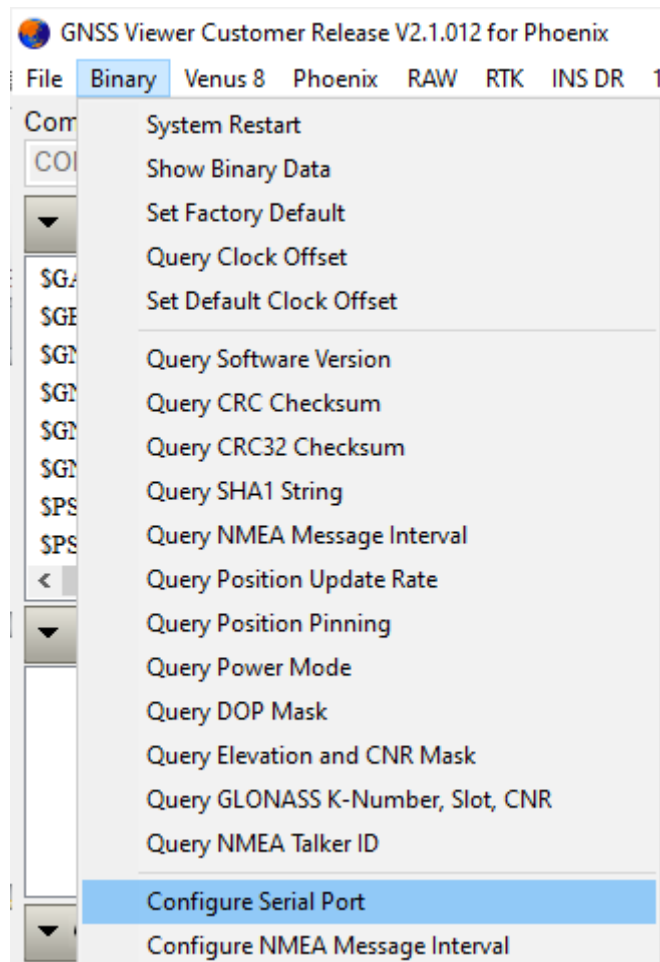

If wishing to change NMEA solution output updated rate, from Binary pull-down menu select Configure Position Update Rate, select desired update rate and Update to SRAM+Flash.

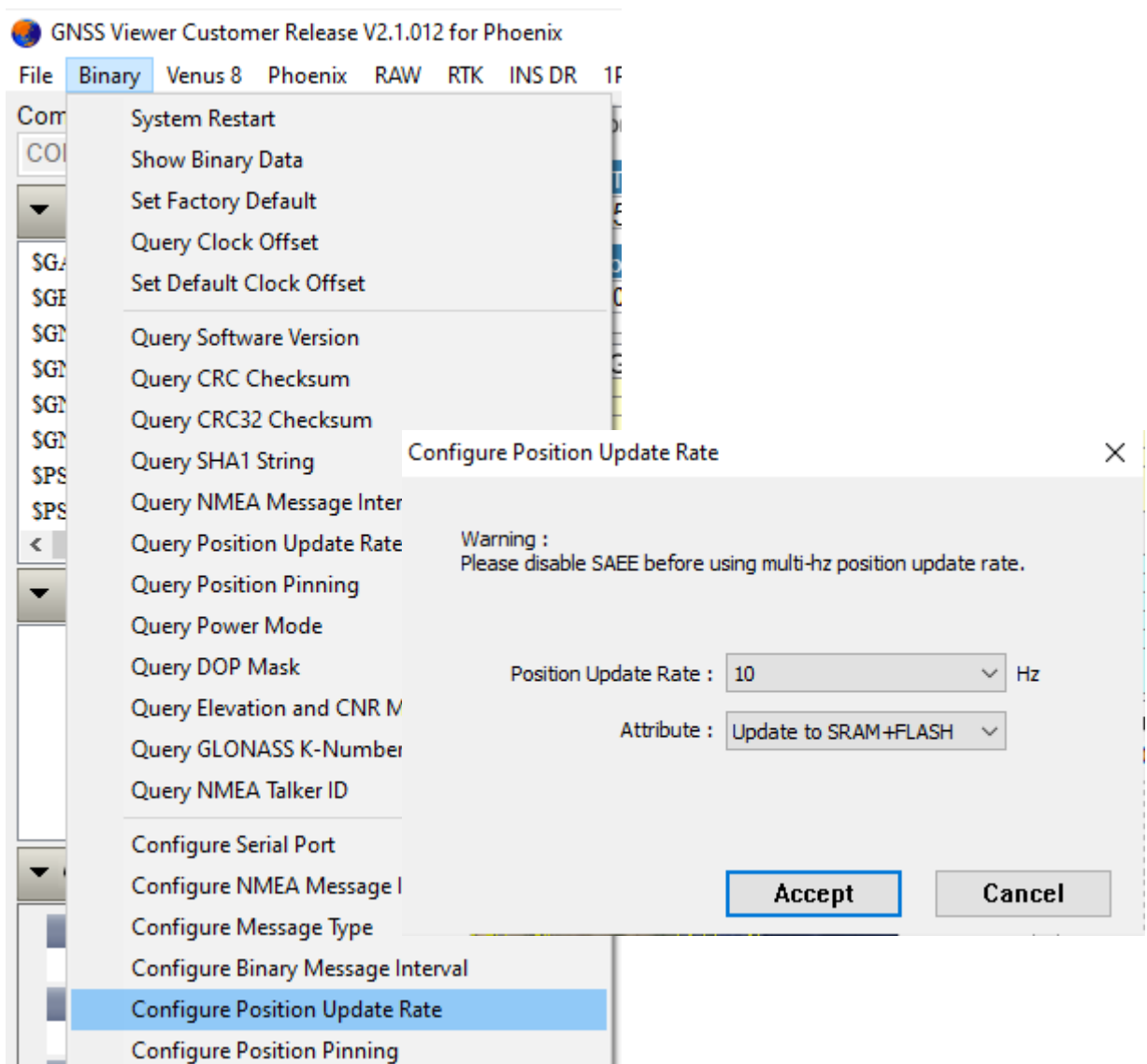

When changing to higher update rate, make sure baud rate in use can accommodate it. If baud rate is not fast enough, NMEA message output will be truncated.

6. SET UP NS-HP-GN2 AS RTK BASE

Hook up as below; connect to an UART-to-USB bridge breakout board for connecting to GNSS Viewer running on a Windows PC.

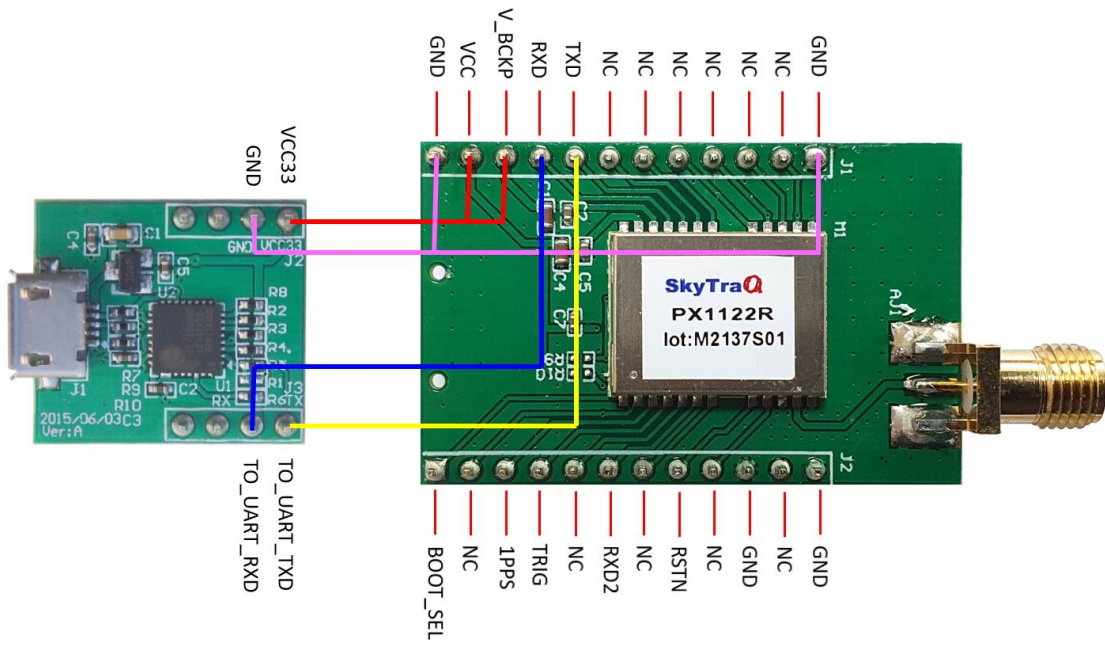

Known Base Antenna Position

When configured as base, NS-HP-GN2 will output its position along with carrier phase raw measurement data over UART TXD. If base NS-HP-GN2 antenna will be placed at a location with known position, the position information can be set into NS-HP-GN2 using GNSS Viewer.

From RTK pull-down menu, select Configure RTK Mode And Operational Function, select RTK base mode, select Static Mode and enter antenna latitude/longitude in degrees and ellipsoidal height in meter, update to SRAM+Flash.

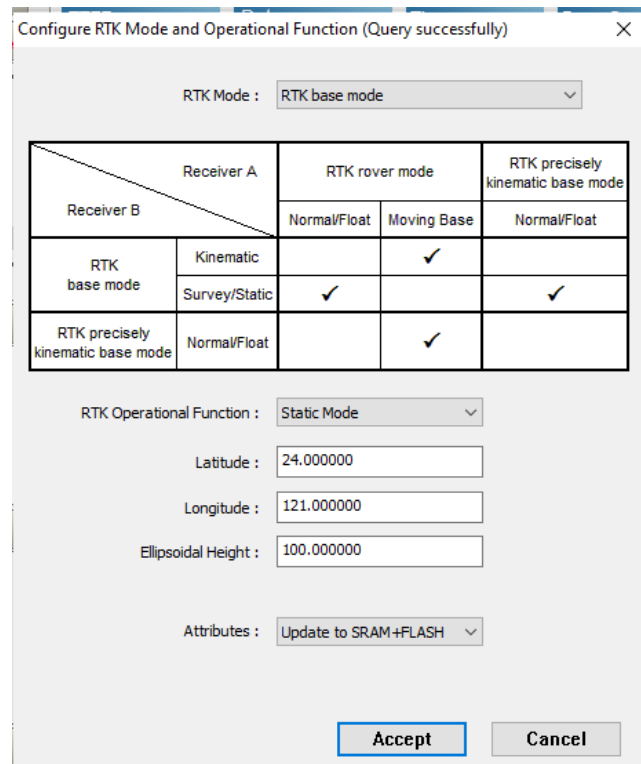
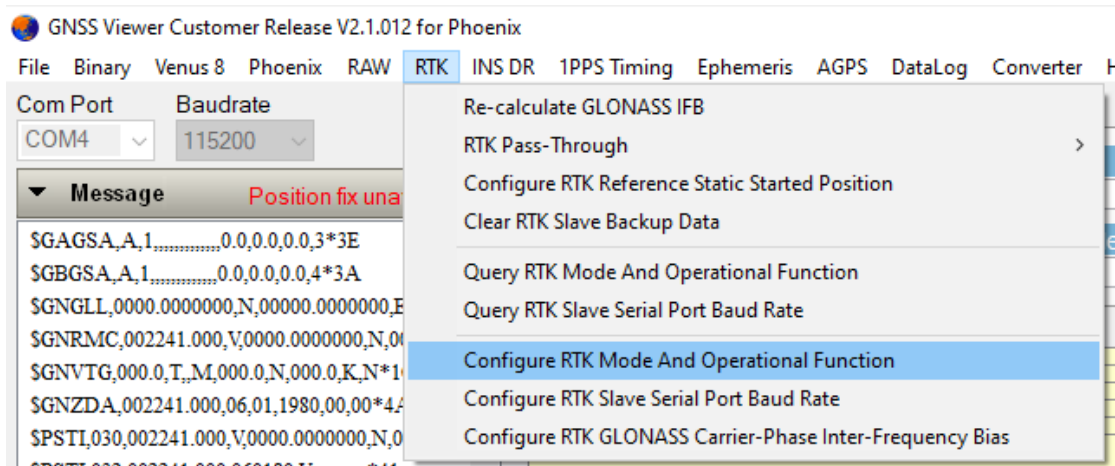

Unknown Base Antenna Position

If base antenna position is unknown, set to let it survey for 60sec upon power up. From GNSS Viewer RTK pull-down menu, select Configure RTK Mode And Operational Function, select Survey Mode and set Survey Length to 60 and Update to SRAM+Flash.

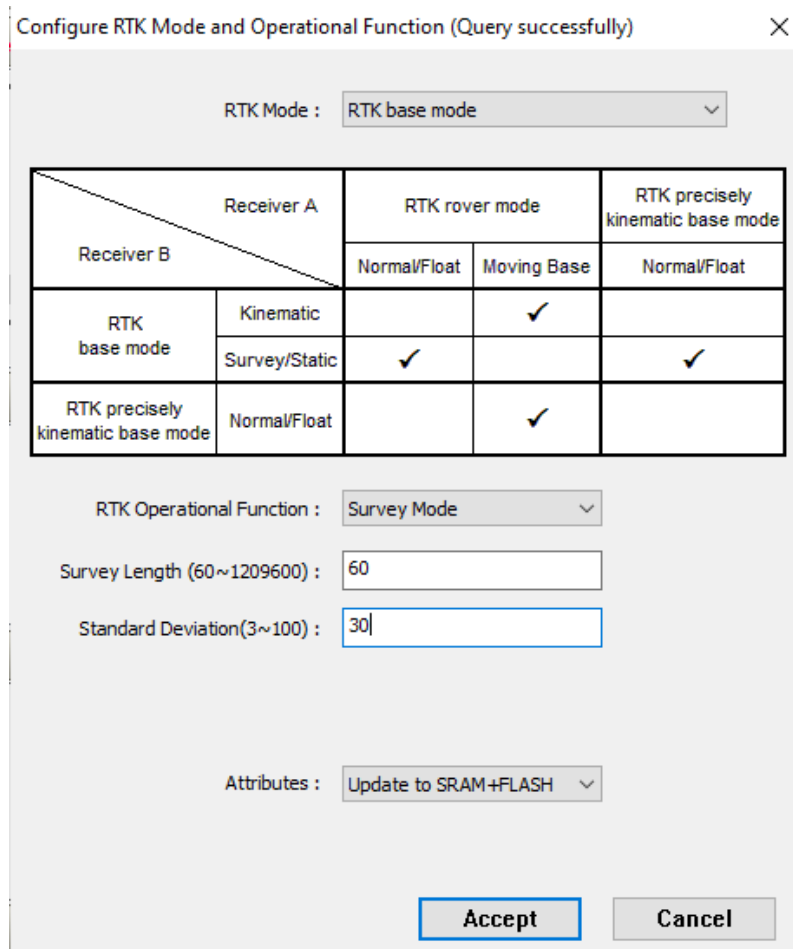
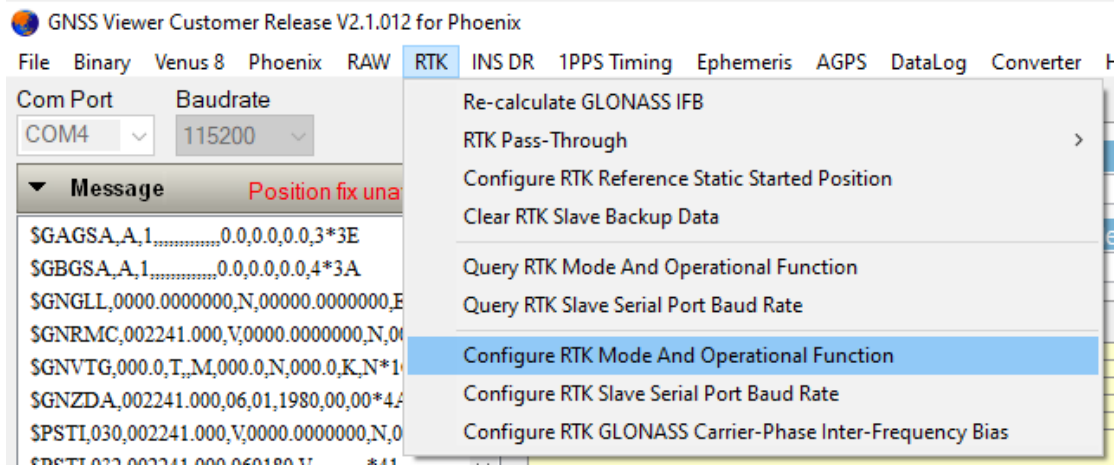

When later in use, after base NS-HP-GN2 gets position fix and self-surveyed for 60 seconds, it enters into static mode. On GNSS Viewer scatter plot view, one will see the blue dot stop drifting around after static mode is entered; Set Origin button may need to be clicked to center the view in order to see the scatter plot. *Next time powering on the base NS-HP-GN2, it will still start from survey mode again, self-survey for 60 seconds, with self-surveyed antenna location at different location unless static mode is chosen and a constant position is entered. To see what the self-surveyed latitude, longitude, and altitude values are, from GNSS Viewer RTK pull-down menu, select Query RTK Mode And Operational Function.*

To use the base at some fixed location, use these steps to self-survey and retrieve surveyed antenna position, then set the antenna position into the base NS-HP-GN2 so that it'll have the same entered position every time it's powered on later. No need to set the antenna position into base NS-HP-GN2 if only testing and becoming acquainted with it.

Once base NS-HP-GN2 has been properly configured, later usage require only connecting an RTK antenna, apply power, and send TXD base output data to the rover NS-HP-GN2.

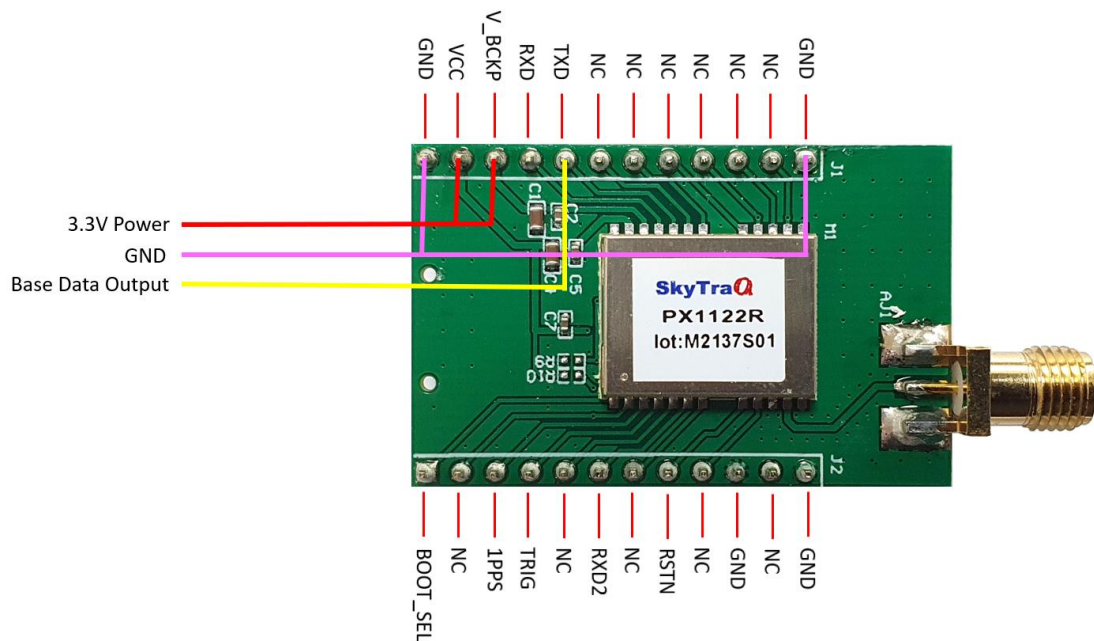

Base Stream Format

After configuring NS-HP-GN2 to RTK base mode, NS-HP-GN2 output in RTCM MSM4 format by default. From GNSS viewer RAW pull-down menu, can select Configure RTCM Measurement Data Out, select Enable RTCM Output, select Stationary RTK Reference Station ARP , select MSM4s and Update to SRAM+FLASH.

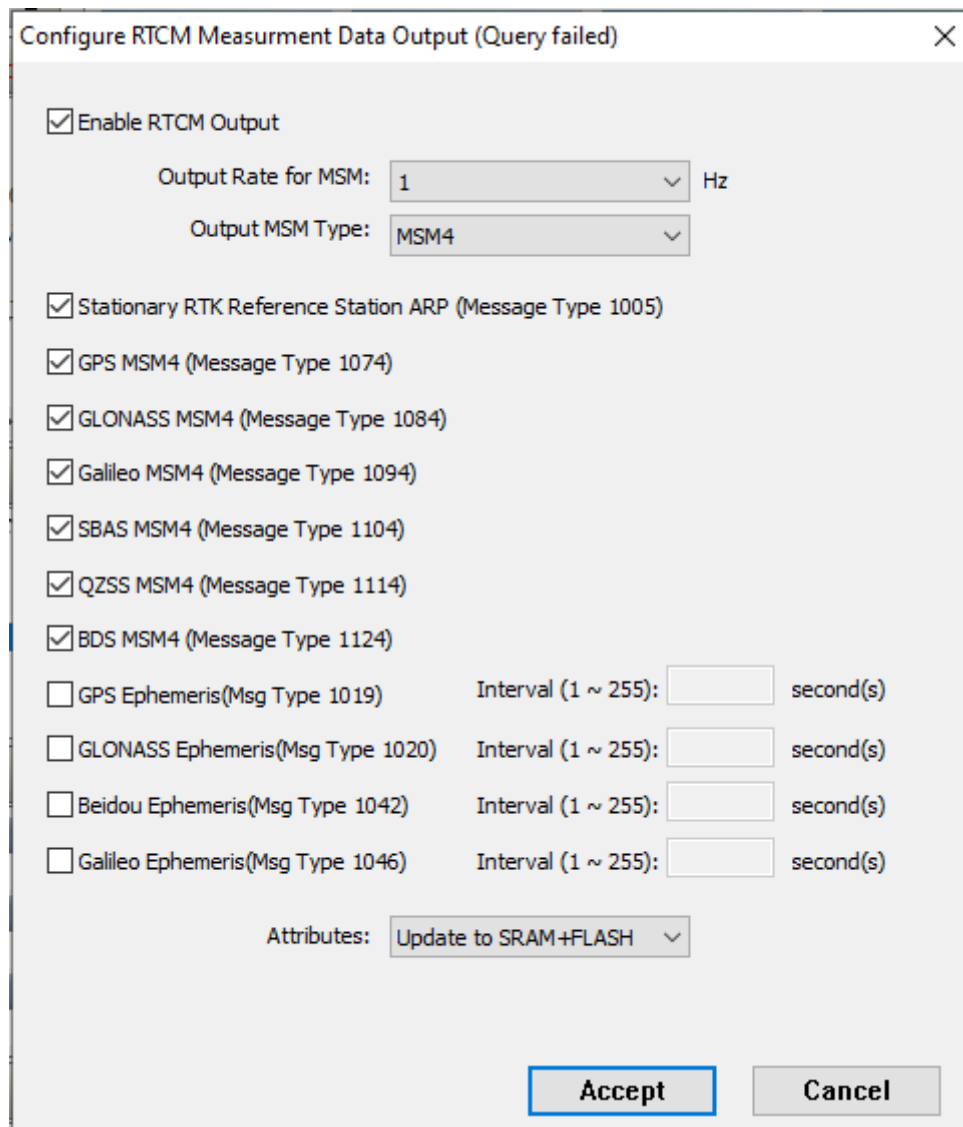
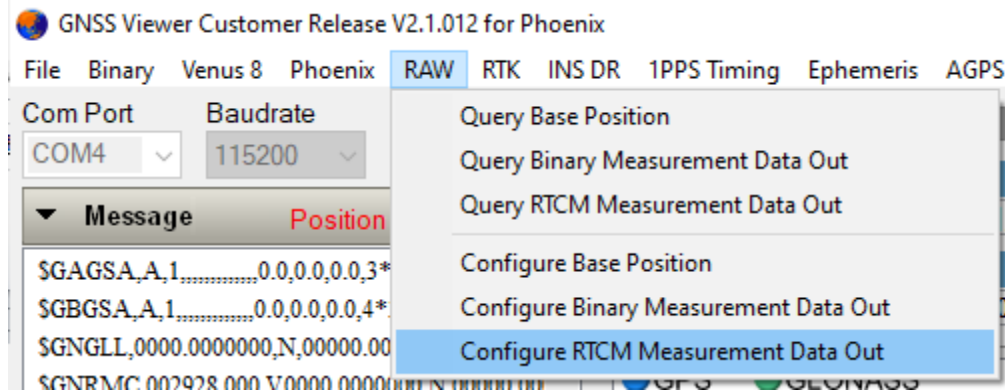

RTCM format has much less data rate requirement than binary raw measurement format. For applications that send base data over radio to the rover, RTCM format is preferred. A minimum of 9600bps data rate is required for MSM4 quad-GNSS operation; can be reduced to 4800 if using only two GNSS constellations.

The RTK base can also be configured to output in SkyTraQ RAW measurement protocol. The outputted messages include:

- 1) Message type 0xDF – Receiver Navigation Status
- 2) Message type 0xE0 – GPS Subframe Data
- 3) Message type 0xE1 – GLONASS String Data
- 4) Message type 0xE2 –Beidou D1 Subframe Data
- 5) Message type 0xE3 –Beidou D2 Subframe Data
- 6) Message type 0xE5 – Extended RAW Measurement
- 7) Message type 0xE6 – General Subframe Data
- 8) Message type 0xE7 – GNSS SV and Channel Status
- 9) Message type 0xE8 –GNSS SV Elevation and Azimuth Status

The necessary message types of base stream used for NS-HP-GN2 RTK rover mode are only “Receiver Navigation Status (0xDF)” and “Extended RAW Measurement (0xE5)”. To decrease the throughput of base stream, other unnecessary message types can be disabled from the base stream. From GNSS Viewer RAW pull-down menu, select Configure Binary Measurement Data Out, disable unnecessary message types, select necessary message types and Update to SRAM+FLASH.

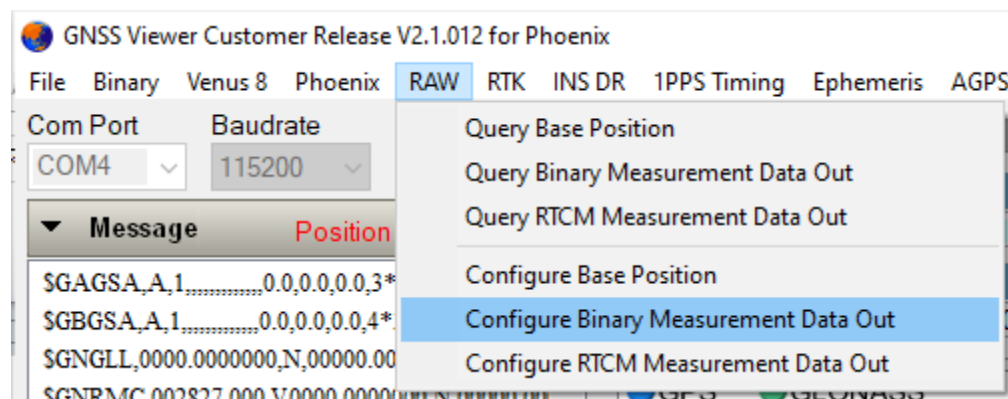

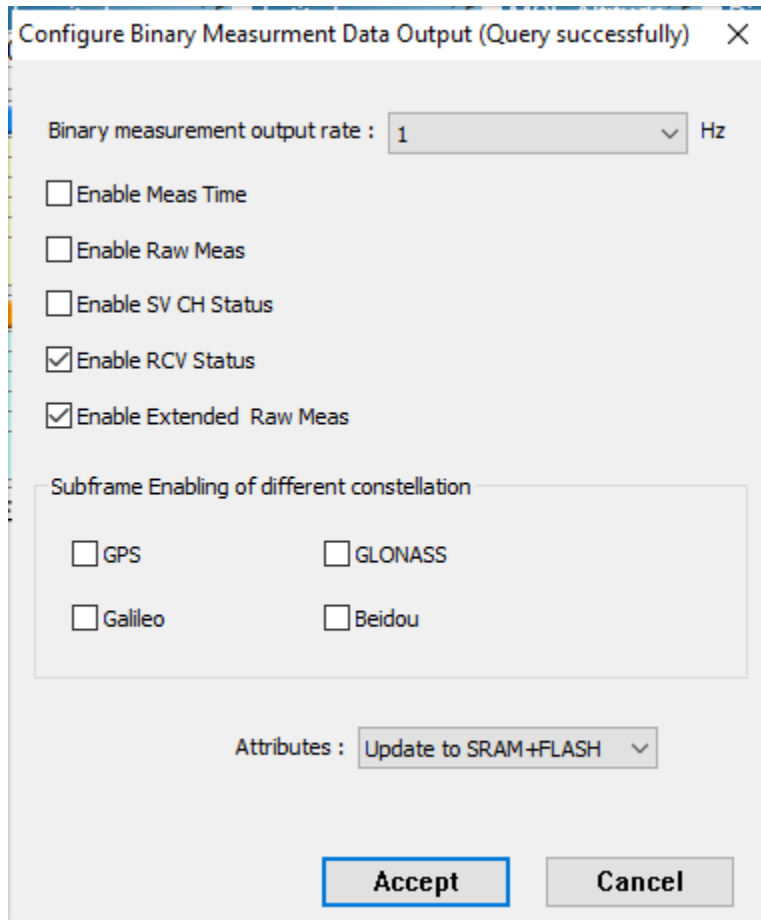

It's deserved to be mentioned that it's necessary to restart rover receiver if the format of base stream is changed.

7. USE NS-HP-GN2 AS RTK ROVER

NS-HP-GN2 is configured as rover during production. If NS-HP-GN2 has been previously configured as base, to re-configure it as rover, hook up as below; connect to an UART-to-USB bridge breakout board for connecting to GNSS Viewer running on a Windows PC.

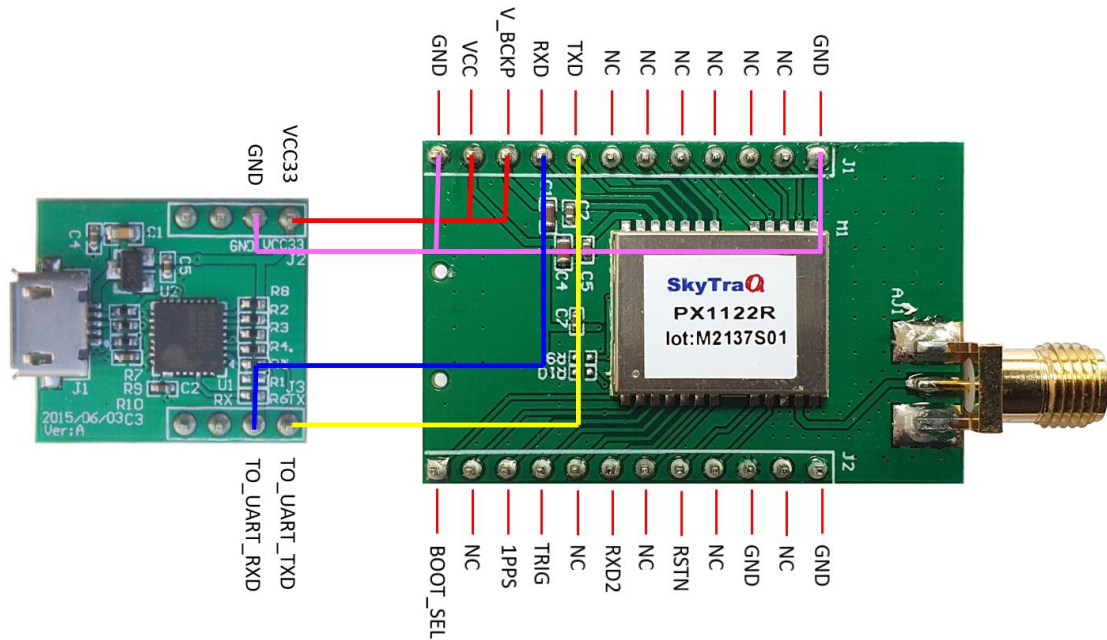

From GNSS Viewer RTK pull down menu, select Configure RTK Mode and Operational Function, select RTK rover mode, Normal RTK Operational Function and update to SRAM+Flash

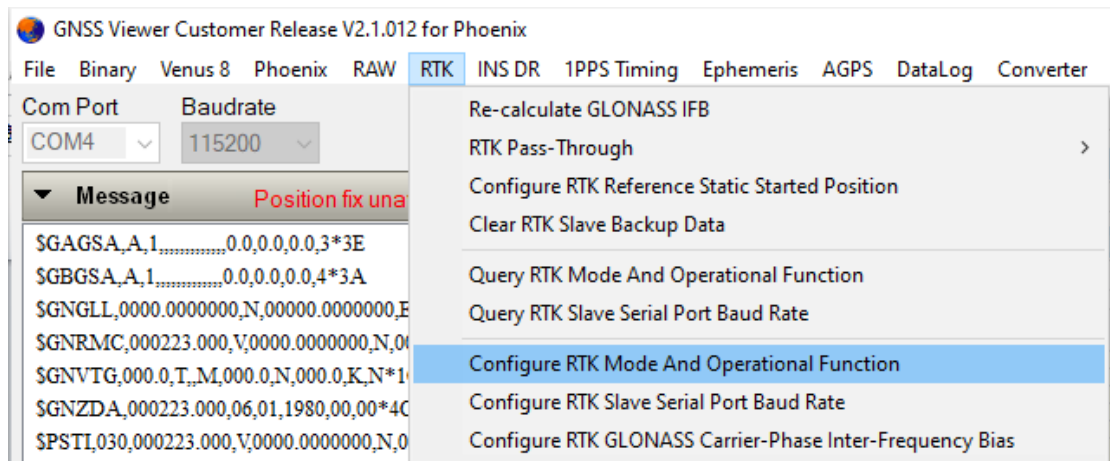

Configure RTK Mode and Operational Function (Query successfully) ✕

RTK Mode :

Receiver A \ Receiver B		RTK rover mode		RTK precisely kinematic base mode
		Normal/Float	Moving Base	Normal/Float
RTK base mode	Kinematic		✓	
	Survey/Static	✓		✓
RTK precisely kinematic base mode	Normal/Float		✓	

RTK Operational Function :

Attributes :

To use NS-HP-GN2 as RTK rover, connect antenna, place antenna at location with clear open sky view, apply base data to UART RX2 input and apply power, NMEA result will come out from UART TXD output. The base data may come from a NS-HP-GN2 base sent over wireless radio, or a remote RTCM 3.x base station retrieved by NTRIP client over Internet and send over Bluetooth-to-Serial or USB-to-Serial interface.

GNSS Viewer 2.1.050 and later versions supports internal NTRIP Client for single UART operation.

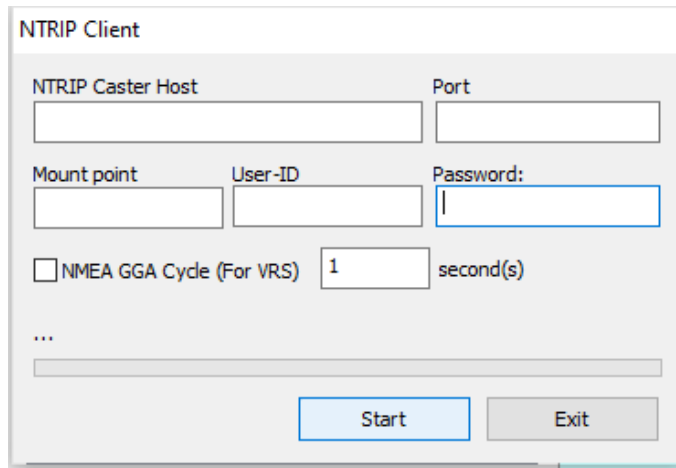
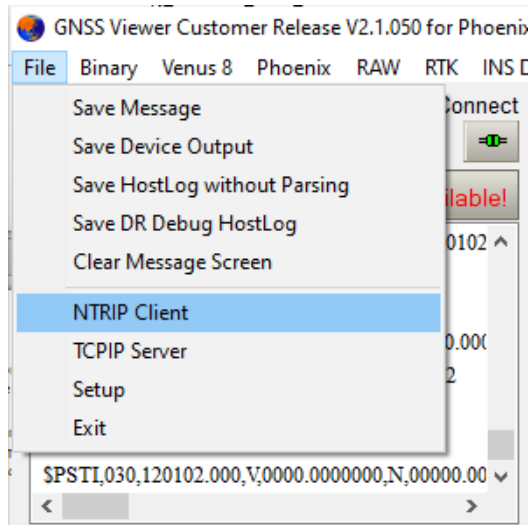

For Precise Positioning, Rover Mode Configuration 2

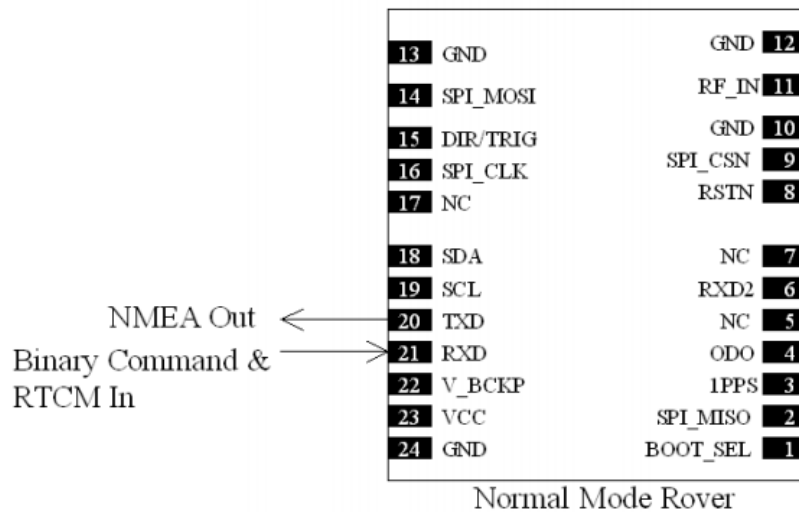

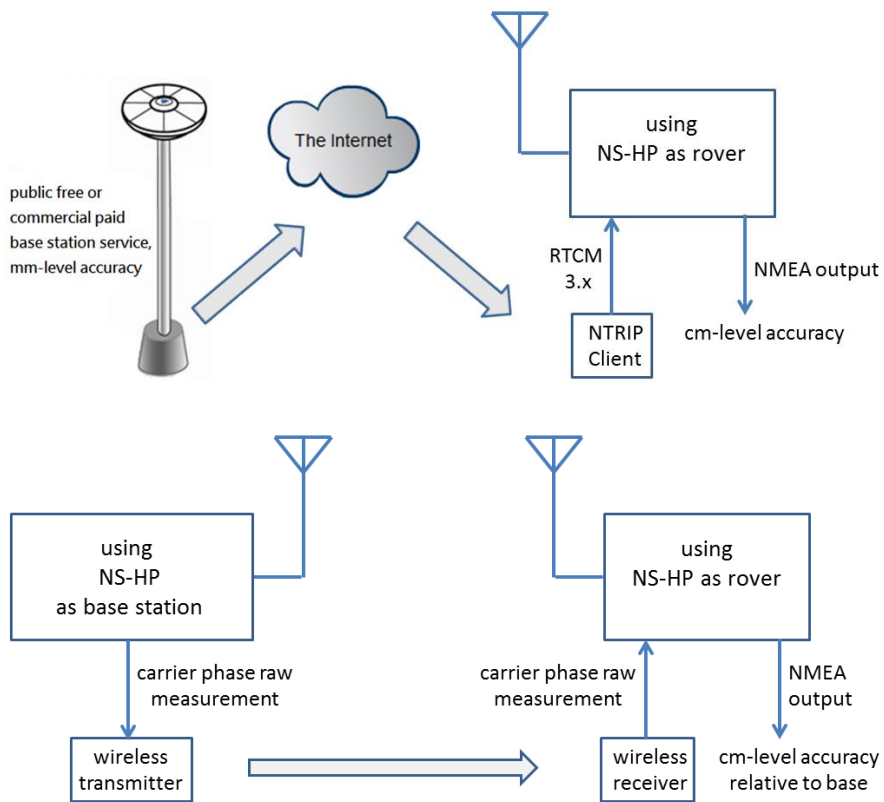
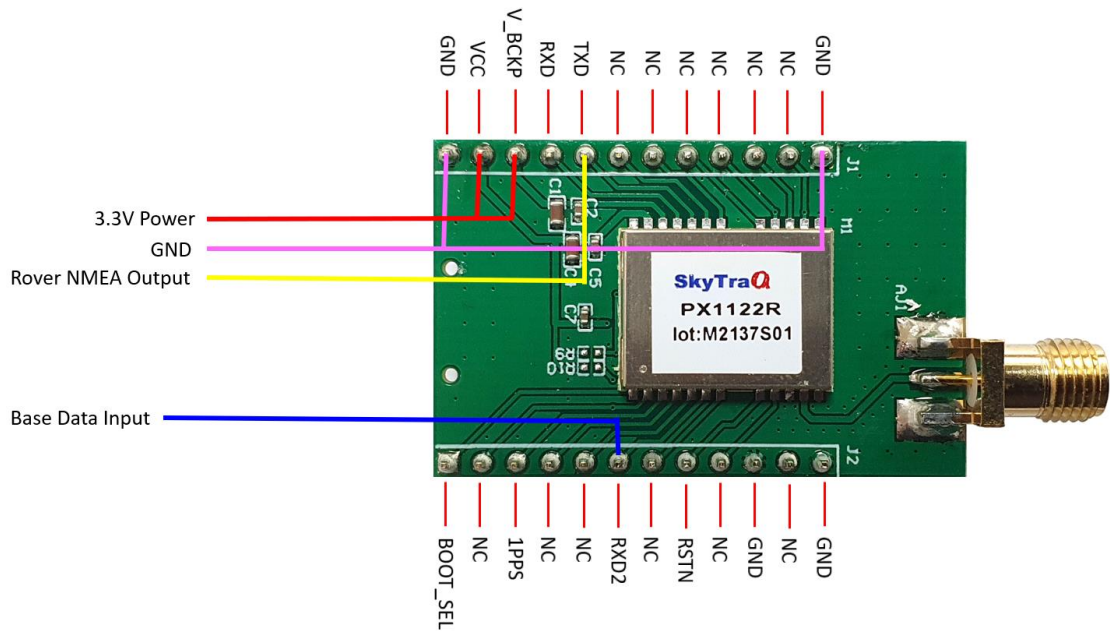

To become acquainted with NS-HP-GN2 RTK rover operation, it's best to first use GNSS Viewer to monitor and interact with it. One possible setup scenario is as below.

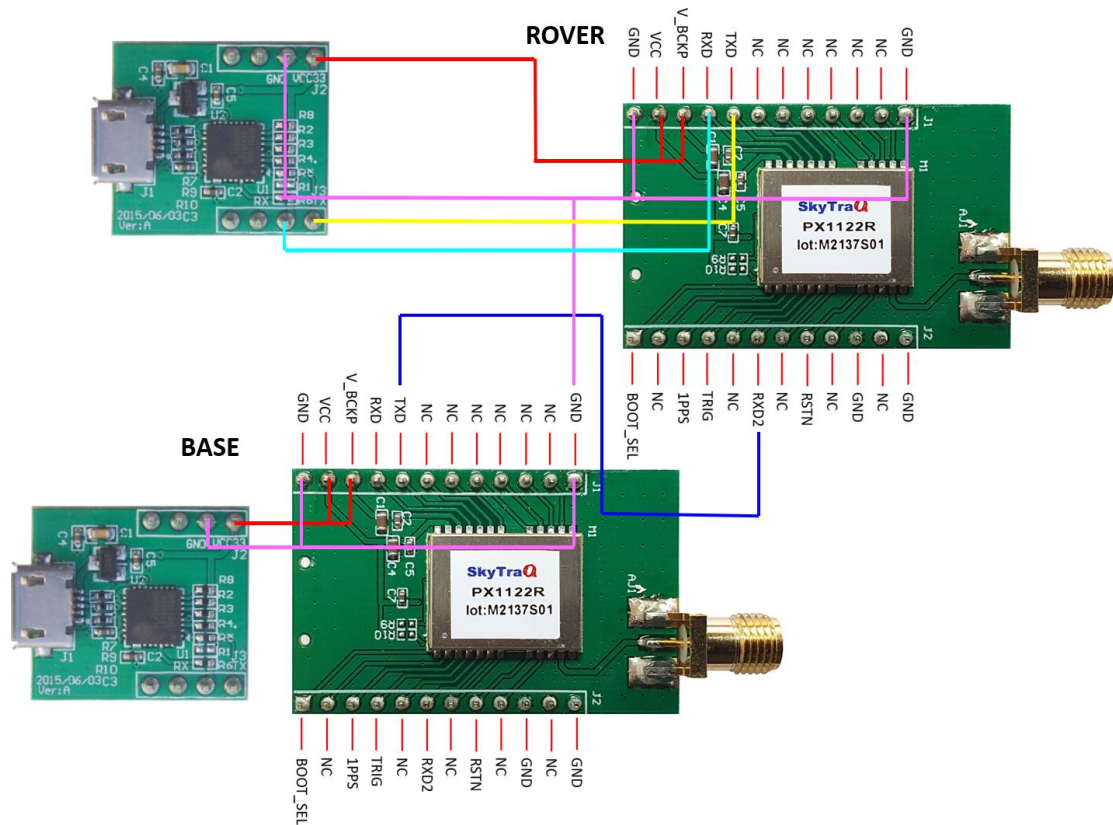

With two antennas connected and placed at location having clear sky view to receive GNSS signal, base connected to laptop USB port for power, rover output NMEA data to GNSS Viewer, one should see rover state going from Position Fix 3D or DGPS mode, to Float RTK, to Fix RTK if earlier mentioned pre-conditions for RTK operation is met.

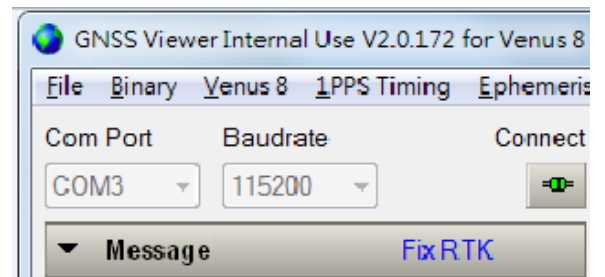
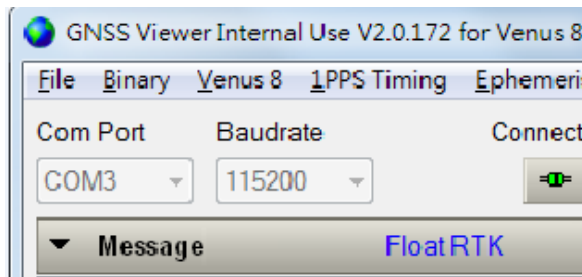
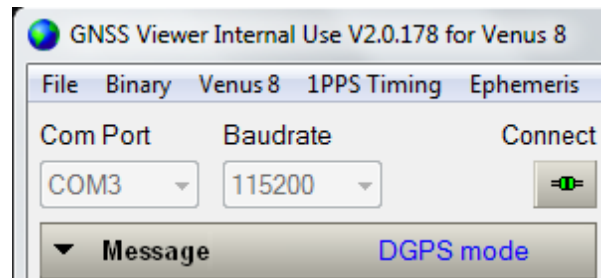
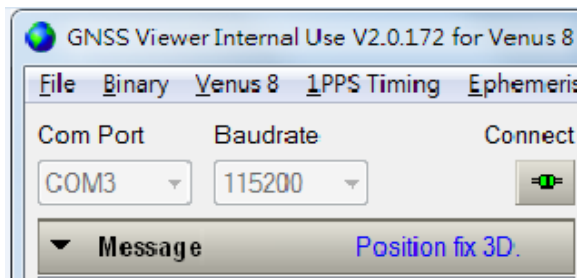

Number values (RTK Age, RTK Ratio, etc.) will be displayed on RTK Info label after Float RTK state is entered. When RTK Ratio number is over 3.0, receiver state changes to Fix RTK; below 3.0, receiver state shows Float RTK.

RTK Age indicates the lag delay in received base data. If RTK Age is 30 or more, indicating lag of 30 second or more, receiver state will show Position Fix 3D, NS-HP-GN2 will not try to compute RTK solution. Large RTK Age indicates some problem with transmission causing severe lag delay.

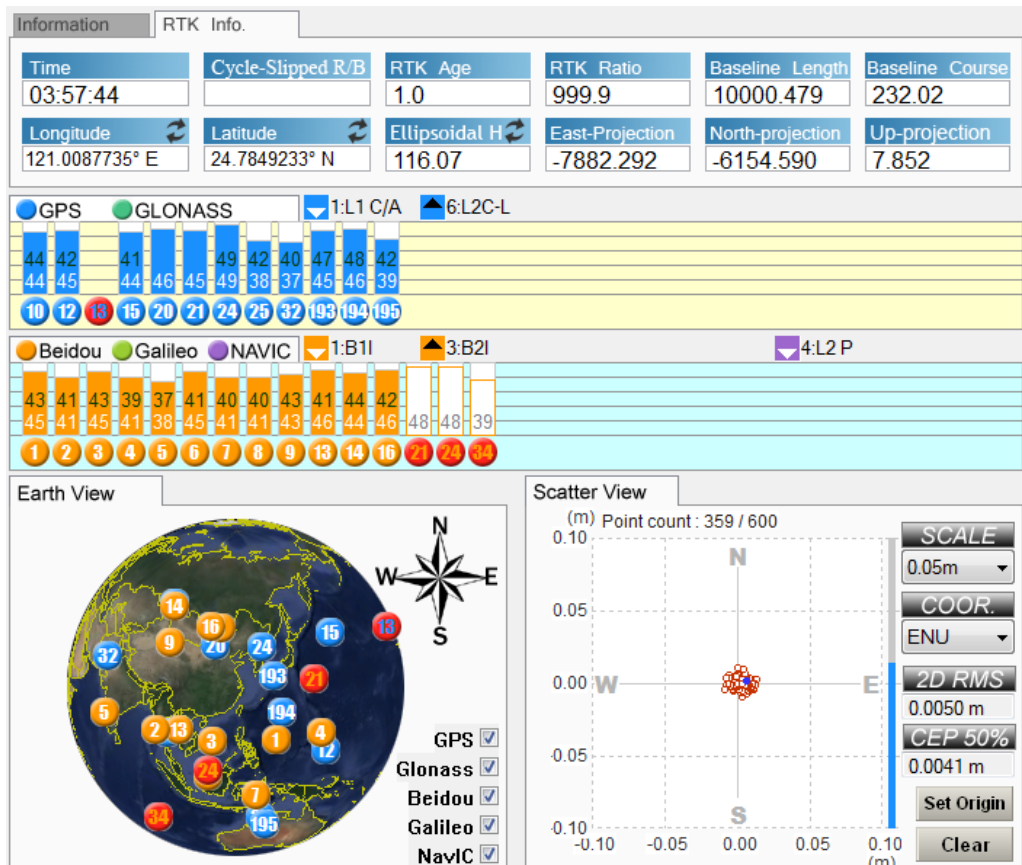

Although a minimum of 6 GPS satellites could result in Fix RTK solution during zero-baseline GPS simulator testing, 8 or more satellites spread across 4 quadrants of the sky is preferred in getting faster RTK fix with reliable result; lesser number of satellites will take longer time getting RTK fix and may sometimes have reported position decimeters off from true location.

Once becoming acquainted with NS-HP-GN2 RTK operation, one can replace base/rover wire connection with wireless radio connection to operate over distance as below shows. The rover NMEA output, besides sending to application microcontroller, can also be sent to a wireless transmitter for monitoring using GNSS Viewer on a laptop with wireless receiver.

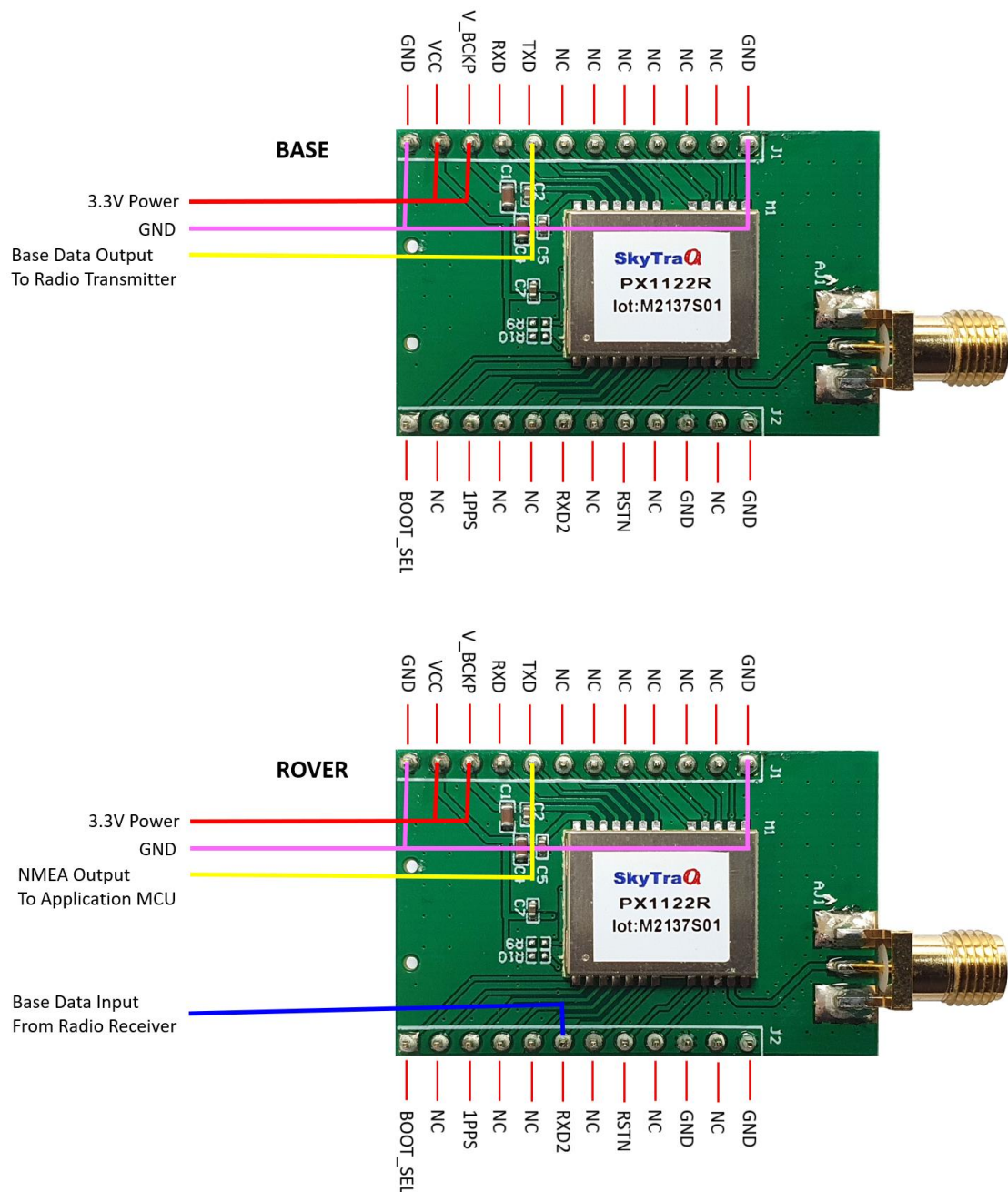

To use NS-HP-GN2 with Android smartphone or tablet, improving its GPS accuracy 100-fold to centimeter-level RTK for the Apps, a tutorial is available here:

http://www.navspark.com.tw/high-precision/#20151204_1

8. MOVING BASE MODE

Normally GPS heading is derived from velocity; when GPS receiver is not moving, it could not have correct heading information. Moving base mode allows reporting of highly accurate heading direction, from base antenna to rover antenna, even when the antennas are static. PSTI,032 message output this

heading and baseline information; THS message gives heading only information; see PX1122R datasheet for details.

The base needs to be set to Kinematic Mode and the rover needs to be set to Moving Base Mode. With the two antennas are at fixed distance from each other, the distance number is entered as the baseline length information.

Configure RTK Mode and Operational Function (Query successfully) ✕

RTK Mode :

Receiver A \ Receiver B		RTK rover mode		RTK precisely kinematic base mode
		Normal/Float	Moving Base	Normal/Float
RTK base mode	Kinematic		✓	
	Survey/Static	✓		✓
RTK precisely kinematic base mode	Normal/Float		✓	

RTK Operational Function :

Attributes :

Configure RTK Mode and Operational Function (Query successfully) ✕

RTK Mode :

Receiver A \ Receiver B		RTK rover mode		RTK precisely kinematic base mode
		Normal/Float	Moving Base	Normal/Float
RTK base mode	Kinematic		✓	
	Survey/Static	✓		✓
RTK precisely kinematic base mode	Normal/Float		✓	

RTK Operational Function :

Please enter a centimeter level accuracy values
Input 0 for unknown or variable.

Baseline length (meter) :

Attributes :

RTK Mode	Remark
Normal	* 1 / 2 / 4 / 5 / 8 / 10 Hz rover only require 1Hz base
Moving Base	* rover require same update rate base
	* maximum 8Hz update rate
	* at 4Hz or higher update rate must use 230400 baud rate to send data over UART

For N-Hz NS-HP-GN2 in Normal RTK mode, it only needs to work with 1Hz base. For N-Hz rover in moving base mode RTK mode, it needs to work with N-Hz base.

For rover in moving base RTK mode, format of the base stream output can be configured to RTCM format for lower data rate and reduced latency.

9. ADVANCED MOVING BASE MODE

Advanced moving base mode allows reporting of highly accurate position, heading direction and baseline information. The heading direction reported by (advanced) moving base mode is the course between north direction and baseline vector (from base antenna B to rover antenna C) direction, so called azimuth. To get both highly accurate position and heading direction information, advanced moving base mode needs totally three receivers:

Receiver	RTK mode	RTK operational function
A	RTK base mode	Static/Survey
B	RTK precisely kinematic base mode	Normal/Float
C	RTK rover mode	Moving base

In below figure SCL/SDA pins are mapped to become UART pin function.

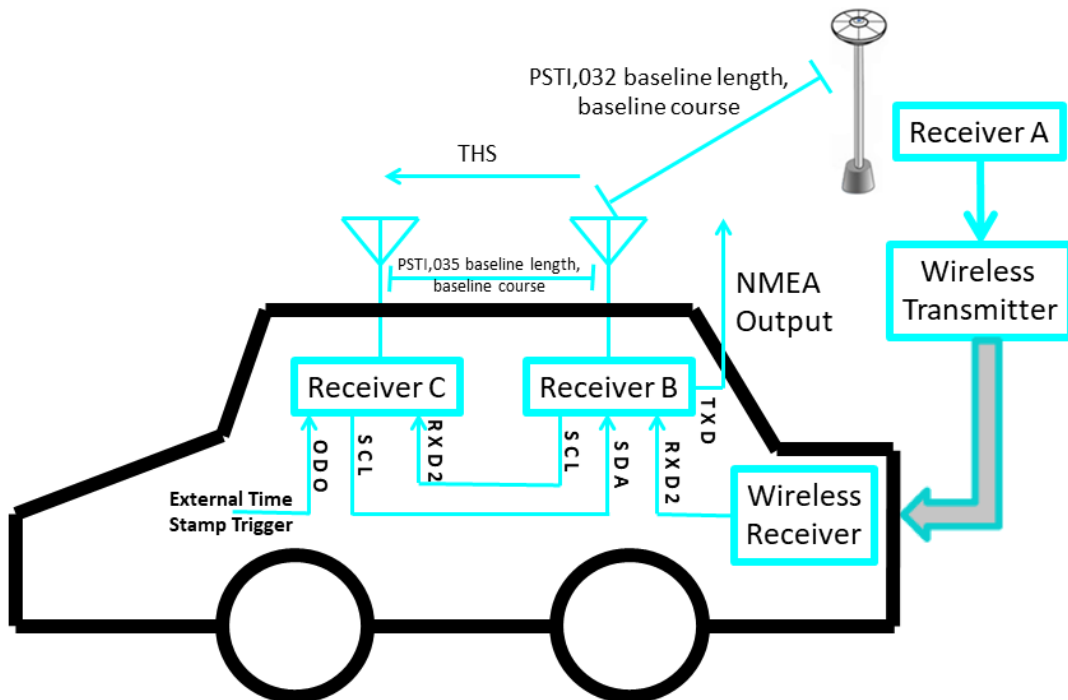

In the sub-system of receiver A and receiver B, receiver A and receiver B are used as base and rover receiver, respectively. However, receiver B not only output NMEA but also binary raw measurement data because it is configured to RTK precisely kinematic base mode. Therefore, receiver B can also be used as base receiver for another rover receiver (whose RTK operational function should be configured to moving base). In the sub-system of receiver B and receiver C, receiver B and receiver C are used as base and rover receiver, respectively. Receiver B can be configured using GNSS Viewer to output in RTCM format to reduce latency, RAW --> Configure RTCM Measurement Data Out

When using advanced moving base mode at 4Hz or higher update rate, receiver B TXD UART need to be configured to 230400 baud rate to output 4Hz or higher update rate NMEA data; receiver C moving base rover RXD2 UART need to be configured to 230400 baud rate in order to receive 4Hz or higher moving base data; receiver B & C I2C mapped UART need to be configured to 230400 baud rate in order to send/receive 4Hz or higher moving base data.

Use below to configure receiver C RXD2 baud rate.

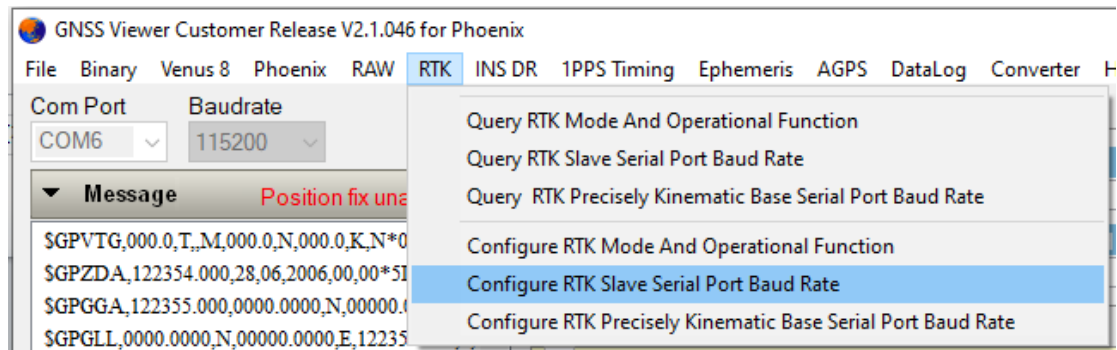

Use below to configure receiver B & C I2C mapped UART baud rate.

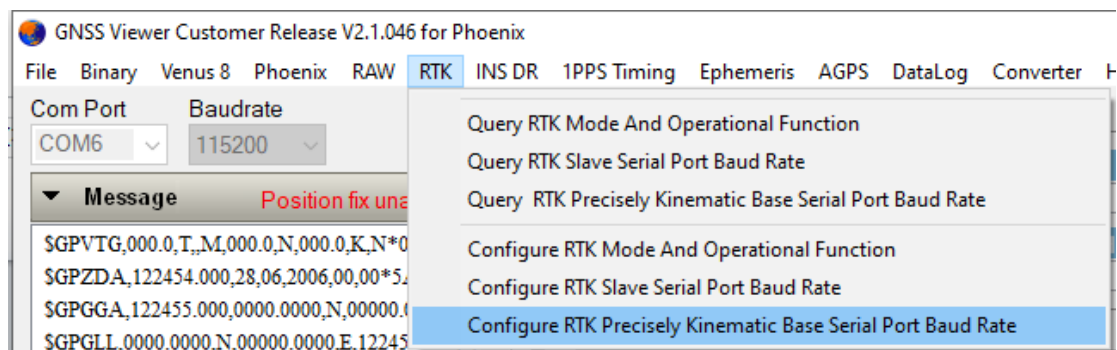

Use below to configure receiver B TXD UART output baud rate

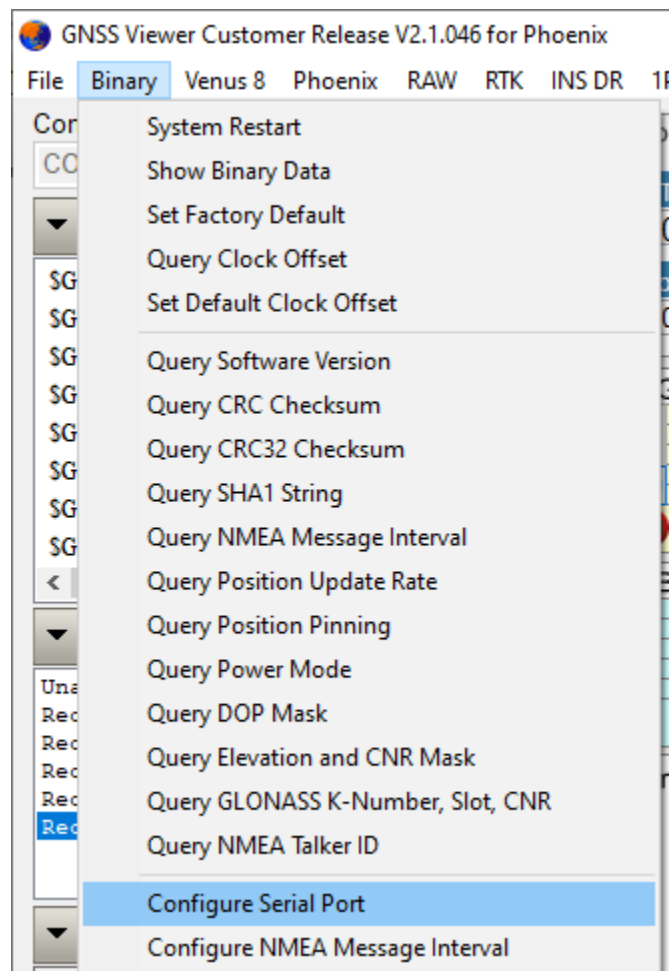

10. ACTIVE ANTENNA CONSIDERATION

External



Survey Grade



Helix



For RTK application, the active antenna must be able to provide signal over 37dB under open sky. Antennas vary in price, from under \$50 to over \$300; they mainly differ in interference rejection capability, multipath rejection capability, antenna phase center stability, and weight. Usually more expensive antenna claims to have superior interference and multipath rejection capability. Phase center of expensive survey grade antenna remains constant as the azimuth and elevation angle of the satellites change; signal reception is unaffected by the rotation of the antenna or satellite elevation. Helix antennas are expensive mostly due to light weight feature for UAV applications.

Under open sky no interference no multipath environments, performance difference between the wide price range of antennas may not be much. Depending on budget and application environment signal conditions, user can choose appropriate antenna for the required application.

11. FIRMWARE UPDATE

When there is firmware update release, it'll be made available on the NS-HP-GN2 web store product page.

To update firmware using GNSS Viewer:

1. Connect TXD and RXD to an UART-to-USB bridge breakout board for connecting to a Windows PC

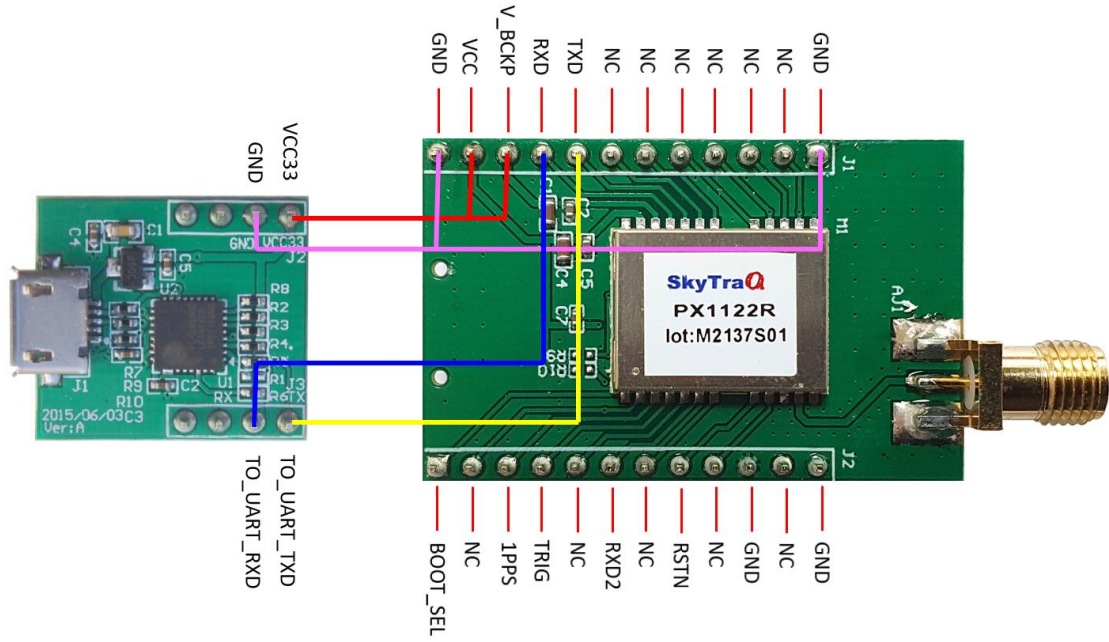

- Connect GNSS Viewer with NS-HP-GN2 using correct COM port and set **Baudrate 115200**, then click the icon under **Connect**. The icon becomes green if they connect correctly.

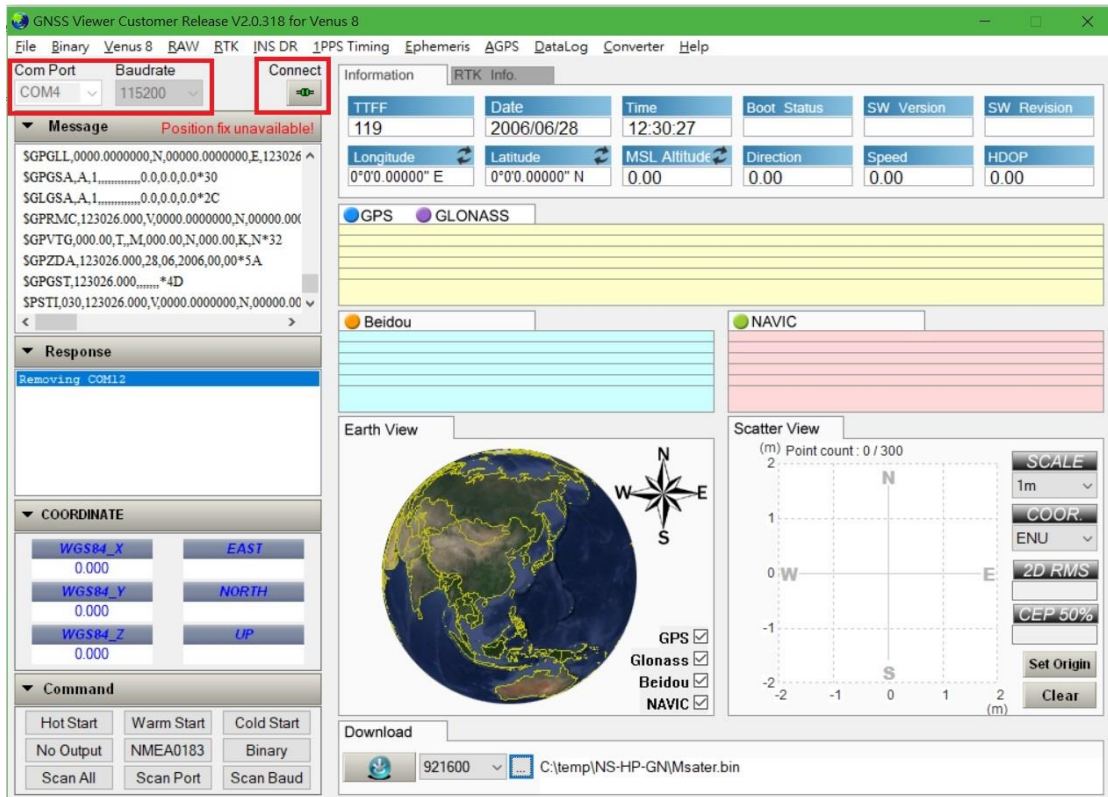

- Click ... to select firmware to update, then click **Download** button to update firmware

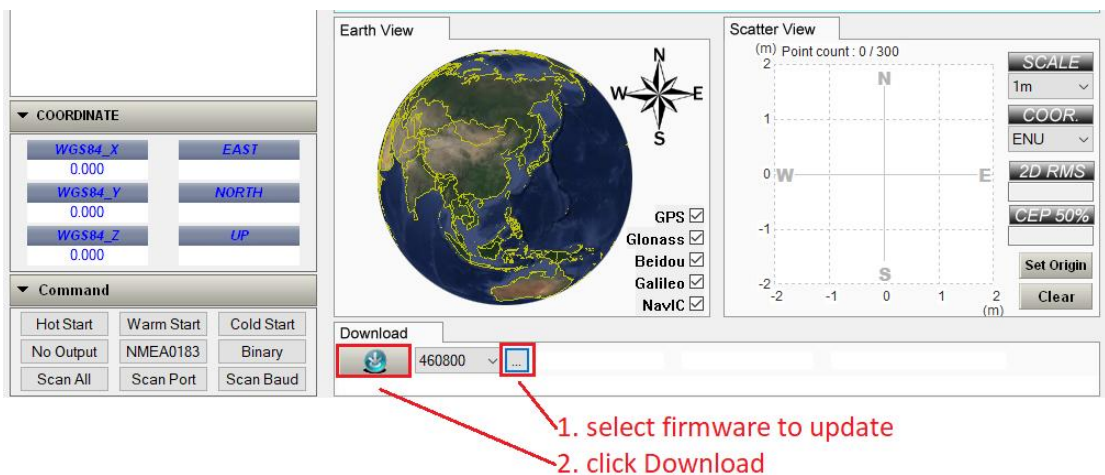

- Firmware has default set to rover mode. If using NS-HP-GN2 as base, procedure for setting up base mode and antenna position needs to be done again after firmware update,

12. POSSIBLE CONNECTION FOR QUADCOPTER APPLICATION

Pixhawk Rover Connection

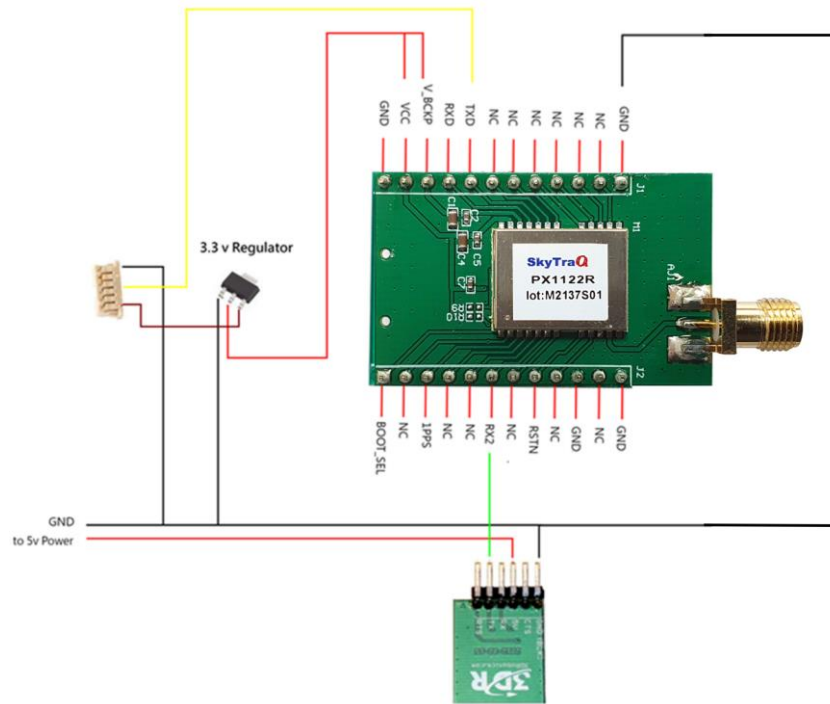

Ground Base Connection

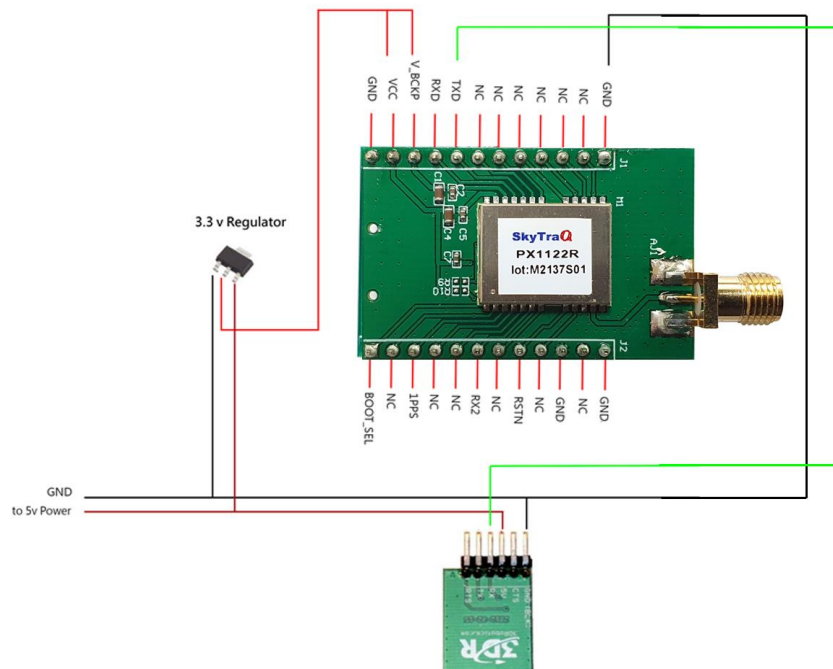

For the 3.3V Regulator in above figure, if you already have the UART-to-USB Adapter breakout board from the web-store, you can modify as below adding a wire connecting pin-stick to capacitor (red wire) and have a 5V-to-3.3V LDO regulator to use.

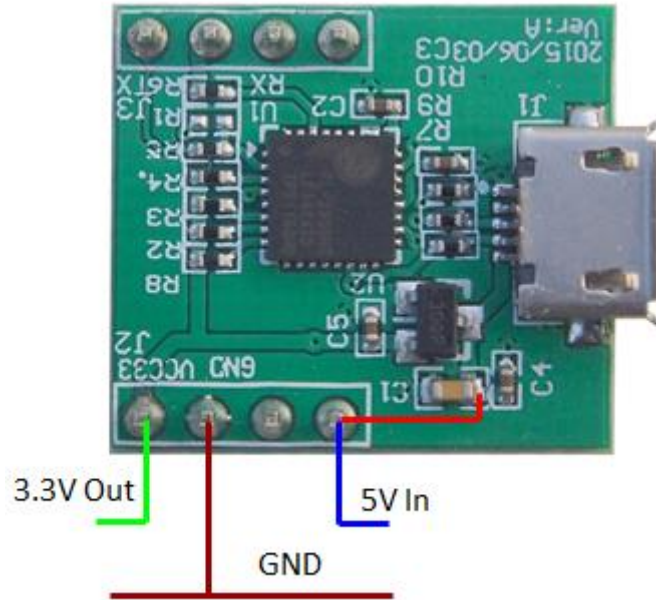

CHANGE LOG

Version 0.9 June 20, 2022

1. Updated figure coloring to make GND connection more distinct.

Version 0.8 May 22, 2022

1. Added GNSS Viewer NTRIP Client explanation.

Version 0.7 May 16, 2022

1. Updated NS-HP-GN2 figures with SMA connector.

Version 0.6 January 22, 2021

1. Section 9 Advanced Moving Base added more descriptions.

Version 0.5 January 11, 2021

1. Added PSTI,035 to Advance Moving Base mode figure on section 9.

Version 0.4 August 21, 2020

1. Update RTCM message types and figures.
2. Added Advanced Moving Base mode

Version 0.3 March 18, 2020

1. Removed Galileo E1/E5b from page-4 footnote

Version 0.2 January 17, 2020

1. Updated supported base input RTCM message types
2. Updated current consumption number

Version 0.1, December 18, 2019

1. Initial release

The information provided is believed to be accurate and reliable. These materials are provided to customers and may be used for informational purposes only. No responsibility is assumed for errors or omissions in these materials, or for its use. Changes to specification can occur at any time without notice.

These materials are provided "as is" without warranty of any kind, either expressed or implied, relating to sale and/or use including liability or warranties relating to fitness for a particular purpose, consequential or incidental damages, merchantability, or infringement of any patent, copyright or other intellectual property right. No warrant on the accuracy or completeness of the information, text, graphics or other items contained within these materials. No liability assumed for any special, indirect, incidental, or consequential damages, including without limitation, lost revenues or lost profits, which may result from the use of these materials.

The product is not intended for use in medical, life-support devices, or applications involving potential risk of death, personal injury, or severe property damage in case of failure of the product.